

# THE MILLSTONE

KURRAJONG ~ COMLEROY HISTORICAL SOCIETY

The Society is dedicated to researching, recording, preserving and promoting the history of the district. Covering the area west of the Hawkesbury River - North Richmond, Kurrajong, Berambing, Bilpin, Grose Vale, Bowen Mountain, Colo, Wilberforce, Ebenezer, Glossodia, Tennyson, Freemans Reach.



**Symbols of Australia**  
*Imagining a Nation*  
Edited by Melissa Harper &  
Richard white

## SYMBOLS of Australia - *Imagining a Nation*

Our K-CHS members had the pleasure of the company of Richard White, as our Guest Speaker at Monday 25th September AGM.

Richard is an Associate Professor, who co-wrote a book called *Symbols of Australia* Imagining a Nation, working in a team with other contributors. Richard was born in Sydney, taught Australian History and the History of Travel and Tourism at the University of Sydney for 23 years. He has published many books and is currently working on the history of tourism in Australia.

Richard's presentation was informative, interesting and humorous. With the visual assistance of PowerPoint, he gave a most entertaining presentation, which included images, quotes and extracts from the book *Symbols of Australia*.

Below and on page three are summaries of two examples from the talk and the book.

**VEGEMITE:** Research in 2006 revealed, the only brand name better known in Australia than the ABC was *Vegemite*. Born out of imitation, the home-grown alternative to marmite, using spent brewer's yeast, became an Australian iconic brand.

100 years ago, in 1923, a product was born and sold in small amber jars. The creator Cyril Callister was recruited by Melbourne based entrepreneur Fred Walker to develop the product. The name *vegemite*, was the winning entry in a competition. Due to poor sales, the product was renamed 'Parwill' standing for 'If Ma Might, then Pa Will', but only in Queensland.

Poor sales continued, so other ingredient suppliers came on-board, the brewing companies, Carlton and United Breweries.

*Vegemite's* success in Australia was owed to the American advertising man (contracted by Kraft) J. Walter Thompson, who was the father of modern magazine advertising.

In 1954, one of the most popular radio jingles appeared, well known to all of us:

*We're happy little vegemites as bright as bright can be,  
We all enjoy our vegemite, for breakfast, lunch and tea,  
Our Mummy says we're growing stronger every single day,  
Because we love our vegemite, we all adore our vegemite,  
It puts a rose in every cheek.*

In 1950, it was wholly American owned by *Kraft Foods Ltd*, but in 2017 it was bought back from *Kraft* by another iconic Australian Company, *Bega Cheese* for \$530 million. *Bega's* shares soared.



Note: **Kraft Vegemite** – proudly made in Australia since 1923 **Bega Cheese Limited**, purchased the VEGEMITE brand in 2017, returning VEGEMITE to Australian ownership for the first time in over 90 years.

In 1982, the Australian rock band *Men at Work* was responsible for *vegemite's* best known literary song-line reference: In the song *Down Under* - "Do you speak-a my language? He just smiled and gave me a vegemite sandwich."

(Cont. p3)

## THIS ISSUE

- Page 2 President's Report
- Page 3 Attention - enquiry re *Valencia*
- Page 4/5 A History of Colo Shire Council
- Page 6 Kurrajong School Fair - Mill Models
- Page 6 Diagram of Water Mill components
- Page 7 From the Archives - Esther Gray
- Page 8 Dates for Your Diary

**K-CHS Christmas Gathering at Glenhuntly**

5pm - Saturday 9th December 2023

## President's Report

Hi everyone,

### AGM

Our 2023 AGM was held at St David's Kurrajong Hts., with a good turnout, up on last year. Our guest speaker, Richard White, was very entertaining and informative. His topic was Australian Icons and how they have changed. See Lesley Bobrige's report on the talk p1 & 3. The committee was re-elected with Mal Bobrige acting as the returning officer. He was very persuasive and managed to get two volunteers to fill the vacant positions. Deb Hallam re-joined the committee and Peta Smith offered to step up. Welcome to you both.

### Blaxland Ridge School House

We held an Open Day at the Blaxland Ridge School House on 16th September. We weren't exactly rushed off our feet but most of the committee were there for a chat and some expertly cooked steaks by Mal at the RFS. Our member Linda Tierney from Murwillumbah was able to spend some time with us.

### Spring Seminar at Goldfinders Inn

There was a good turnout for the seminar and book launch at the Hallam's place on 17th September. It was our first taste of the hot weather, but there were plenty of shade trees. Chris's latest book, "Australia's Earliest Timber Houses", is available online for free download. Just follow the link from our Publications page.

### 2023 Christmas Party

Our members David and Tony are hosting this year's Christmas Party at their delightful property, "Glenhuntly". It is at 1619 Bells Line of Road, just west of the Kurrajong Heights Bowling Club. We decided on a different approach this year to ensure that you all get your very favourite food and drink, **BYO!** We will supply salads and dessert. Feel free to bring any special nibbles you wish to share. Plenty of BBQs available. There is no charge but we ask you to make an online booking so we know how many to expect.

### 2024 Calendar

Our 2024 Calendar is now out. Anyone who pre-ordered should have received their copies by now. We still have quite a few available, despite the freight company rough handling one of the boxes and wrecking a few copies :- ( You can order online for delivery by post or collection at the Christmas Party.

### Next Year

We have a number of ideas on the go for tours next year, including an overnight excursion to Hill End and environs. Have a chat to Frank Holland for more info. There will be details in a later edition.

I mentioned a tour of SES and RFS headquarters at the AGM. This was going to be in November but has now been moved to early next year.

Have a **Merry Christmas everyone** and I hope we see lots of you at *Glenhuntly*.

David Griffiths  
 president@kurrajonghistory.org.au  
 Ph: 4567 8999  
 Mob: 0498 646 899

## KURRAJONG – COMLEROY HISTORICAL SOCIETY INC.

PO BOX 174 KURMOND NSW 2757

ABN 68930834921

Print ISSN 2201-0920 - Online ISSN 2202-6320

### Committee

**President** .....David Griffiths

**Vice President** .....Lesley Bobrige

**Secretary** .....Jennifer Griffiths

**Treasurer** .....Pat O'Toole

Frank Holland Valerie Holland

Deborah Hallam Suzanne Smith

Peta Smith

**Millstone Editor**.....Suzanne Smith

**Webmaster** .....David Griffiths

**Digital Archivist** .....Jenny Griffiths

**Family History** .....Valerie Birch

**Librarian/Accessions** Valerie Birch

**Public Officer** .....David Griffiths

**Grants Officer** .....Frank Holland

**Hon Auditor**.....Marilyn McCarthy

**DISCLAIMER:** Views & opinions expressed in the newsletter originate from many sources and contributors. Content does not necessarily represent or reflect the views or opinions of K-CHS, its committee and members. Every effort is taken to ensure accuracy of articles. If errors are found feedback is welcome.

secretary@kurrajonghistory.org.au



## KURRAJONG-COMLEROY HISTORICAL SOCIETY



2024 CALENDAR

### K-CHS Calendar 2024

Featuring images from our image archive collection, and published by the Kurrajong-Comleroy Historical Society. If you are local, we will deliver, otherwise we will forward your calendar via post. The Calendar has one page per month. \$15.00 (\$4.00 postage)

ORDER online:

<https://www.kurrajonghistory.org.au>

**SYMBOLS of Australia - Imagining a Nation (cont.)**

**COOEE:** Our ' national call ' distinctive to Australia and connected with the bush and easy to reproduce.

How widespread it's use was among the First Peoples and for how long, is uncertain. Perhaps, initially they mimicked the call of the 'Cooee' bird, or the 'koel ', whose call can be heard down the east coast of the continent.

'Cooee' has many uses, a work-calling, a greeting, a call to lunch, or even a general eruption of high spirits.

Once war broke out in 1914, when Australians answered the 'Empires' call, it was inevitable that the call would be represented as a 'cooee'. It became a motif for recruitment posters and in patriotic songs.

From the 1920's the cooee fell out of favour as a national symbol, but it is still used in the bush, and across backyard fences for everyday purposes. It was even used by Australians at the rugby in London in 1957.

Other Australian Symbols written about in the book are ; Southern Cross, kangaroo, crown, map, stamps, gum tree, shark, boomerang, billy, Miss Australia, flag, wattle, Coat of Arms, digger, Australia House, The Great Barrier Reef, Sydney Harbour Bridge, Lifesaver, Pavlova, Holden, Uluru, and the Sydney Opera House

**Article by Lesley Bobrige  
K-CHS Vice President**



**ATTENTION: An ENQUIRY re "Valencia"**

We would like to find any information about a house called "Valencia" which was moved from Seven Hills to Bilpin in the early 1970s. For example, where was it relocated to in Bilpin, is it still there, who were the owners? Please contact the secretary with any information: [secretary@kurrajonghistory.org.au](mailto:secretary@kurrajonghistory.org.au)

This photo of "Valencia" was taken about 1970, after it had been transported in two halves from Seven Hills. It may not have been called "Valencia" when relocated to Bilpin. There appears to be some uncertainty as to when it was actually moved to Bilpin.

Photo from: "Seven Hills in Pictures".  
Blacktown and District Historical Society 2012

Kurrajong (Heights) 1918  
Oil on Canvas 36 x 51 cm  
by Antonio Dattilo Rubbo  
Housed in a timber frame.

This painting was possibly exhibited at the Art Society of NSW in 1918 as *Kurrajong Heights*. It was priced at 12 Guineas and accompanied a painting now in the QLD Art Gallery titled *The Pea Picking Kurrajong 1918*.

See *From the Archives* in the Jan-Feb MILLSTONE Newsletter 2023 (page 7) for a reference to Rubbo's art work *Pea Picking Kurrajong 1918*.

The *Kurrajong Heights* painting SOLD last month from the *Day Gallery* Govetts Leap Road Blackheath NSW



*Kurrajong (Heights) 1918* by Antonio Dattilo Rubbo (1870-1955)

### A History of COLO SHIRE COUNCIL – The Three Ridings West of the Hawkesbury River - 1906

**Colo Shire** was a local government area in the Sydney region of New South Wales. One of 134 shires created after the passing of the *Local Government (Shires) Act 1905*.

In accordance with the (Shires) Act, 1905, the Shire of Colo (Shire no. 118) was declared into existence (1). As Gazetted on 7 March, 1906, Colo Shire included the following boundaries:

*Commencing at the junction of Wollemi Creek and the Colo River; bounded by the Colo River and Wollongambe Creek; the parishes of Wollongambe and Irvine; the Grose River; the western and southern boundaries of the parish of Nepean; the right banks of the Nepean and Hawkesbury Rivers to Wiseman's Ferry; bounded by the parishes of St Albans, Wallambine and Lockyer; the southern watershed of Yengo Creek; the Macdonald River; bounded by the parishes of Putty, Tollagong, Sturt, Coricudgy, Jamieson, Innes and Wirraba; and the Wollemi Creek to the point of commencement (2).*

In May 1906, the Colo Shire was divided into three ridings, in accordance with the Local Government (Shires) Act, 1905 (3). This same Act also resulted in the appointment of a Temporary Council, whose tasks included making all necessary arrangements for the election of the first Council (4). Cecil S Icely was appointed Returning Officer, and the first elected Council were:

"A" Riding - Arthur Charles Anderson; Edward Quinn.

"B" Riding - Edward Thomas Bowd; Henry Albert Wilson.

"C" Riding - James Edward McMahon; John Lamrock, who was also elected President of Colo Shire Council (5).



Colo Shire Council 1906 - Members elected from the 3 Ridings. **Back Row L-R** J. McMahon, A. Anderson, W. Gosper, H. Wilson, E. Bowd. **Front Row L-R** A. Adams, J. Lamrock, C. Icely (Shire Clerk) John Lamrock is President and is seated centre front.

On 19 December 1917 the north-western part of Colo Shire was united to the Blue Mountains Shire. Described as:

*Commencing at the intersection of Wollangambe and Bowen's Creeks; along Bowen's Creek to, and including, the western boundary of portion 16, parish of Bilpin; to the Bell's line of road, and along this road to Richmond; south-westerly to the boundary of the parish of Irvine; parish of Irvine boundary and along Wollangambe Creek to the point of commencement (6)*

In February 1925 parts of "B" riding were united to Castlereagh, Richmond and Windsor Municipalities and Baulkham Hills Shire, though "A" and "C" ridings were unaffected (7). October 1956 saw a major change to the boundaries of Colo Shire, as parts of "A" riding were united to Patrick Plains Shire. The boundaries of "B" and "C" ridings were also altered within the Colo Shire (8).

In December 1960 the boundaries of Colo Shire were again changed as 6,040 acres of "C" riding were transferred to the City of Blue Mountains, "A" and "B" ridings remained as 1956 (9).

The Shire Offices were in Wilberforce (the building is now the Hawkesbury RFS Headquarters). Other towns in the shire included North Richmond, Sackville, Glossodia, Kurrajong, St Albans, Ebenezer, Bilpin, Berambing, Grose Vale, Grose Wold, Tennyson, Freemans Reach

Colo Shire amalgamated with the Municipality of Windsor to form Hawkesbury Shire on 1 January 1981 per the *Local Government Areas Amalgamation Act 1980*.

So the final major change occurred in 1981, as what remained of Colo Shire was united to the Municipality of Windsor, the result of this amalgamation being the creation of Hawkesbury Shire (10).

*Colo Shire Council had operated for seventy-five years until amalgamation with Windsor Municipal Council in 1981, forming Hawkesbury Shire Council, city status was granted in 1989, forming Hawkesbury City Council.*

In summary, although land was transferred to Blue Mountains City Council on more than one occasion and boundaries changed over the years, the area controlled by Colo Shire was still 2,646 square kilometres in 1960.

The land stretched from north of Putty to Castlereagh and from Mount Bell to Mount Manning, from the junction of Wollemi Creek and the Colo River to the parishes of Wollangambe, Irvine, St Albans, Wallambine and Lockyer, Mount Wilson, the Grose River, down to Yarramundi and the right banks of the Nepean/Hawkesbury River all the way to Wisemans Ferry crossing.

#### Endnotes & References:

(1) NSW Government Gazette, 7 March, 1906, p 1605.

(2) *ibid.* p 1605

(3) NSW Government Gazette, 16 May, 1906, p 2966.

(4) *ibid.* pp 2979, 2981.

(5) NSW Government Gazette, 19 February, 1908, p 1146.

(6) NSW Government Gazette, 21 December, 1917, p 6856.

(7) NSW Government Gazette, 27 February, 1925, p 1065.

(8) NSW Government Gazette, 19 October 1956 pp 3029 - 31.

(9) NSW Government Gazette, 23 December 1960 pp 4080 - 82

NOTE: (10) Hughes, J N, (editor), *Local Government Local History: A Guide to NSW Local Government Minute Books and Rate Books*. Royal Australian Historical Society, Sydney, 1990. **(cont. page 5)**

## A History of COLO SHIRE COUNCIL (cont.)

### Some interesting notes

The first meeting of the Temporary Colo Shire Council met at *Windsor Court House* on 13 June 1906. The first election took place on 24 November 1906 and the first elected council met at the *Old Retreat Inn* in Wilberforce on 6 December 1906.

The Colo Shire Council Chambers at Wilberforce were constructed in 1910 and extended in 1959. Additions to the building were made in 1959, then later in 1979.

The former Colo Shire Council Chambers are located in George Road, Wilberforce, New South Wales. The Local Government (Shires) Act of 1905 enabled the formation of local councils which had the power to levy rates on freehold property and had the responsibility for the repair of roads and the provision of services. Colo Shire was inaugurated in March 1906. There were just over 1,000 eligible voters at the time and the first election took place on 24 November 1906. The selected representatives held their first meeting at the *Old Retreat Inn*, George Road Wilberforce on the 6 December that year. Meetings were held in this venue until the opening of the new chambers on the high side of George Road in September 1911.

Bank accounts were opened with the Commercial Banking Company of Sydney, Windsor Branch, and the first loan was for 350 pounds with an interest rate of six per cent. At the time, each councillor had to sign a personal guarantee with the bank to repay the loan if Council defaulted.

All minutes of the general and special meetings of the Colo Provisional Shire Council were created at least monthly and recorded chronologically. The 1906 Provisional Council under s.7 (a) of the Local Government (Shires) Act 1905, allowed for the appointment of Temporary Councillors who were required to organise and supervise the preparation of electoral rolls and to make all the necessary arrangements for the election of the first council.

As noted earlier the Temporary Councillors were appointed on 16 May 1906, and held their first meeting on 13 June 1906. The Council organised an election to take place on the 24 November 1906. The general meetings record inward and outward correspondence received by the Council, motions put to the Council, reports of committees and other relevant items of business. The minutes document the variety of activities for which the Council was responsible including financial management, and preparation for Council elections.

This minute book is not arranged in strictly chronological order, and contains outwards correspondence. The minutes have also been damaged at some stage, and have been given a protective covering. Special Meetings were called to record a specific issue. Reports were generally also tabled at these Meetings relating to the subject.

These minute books were initially created under s.49 of the Local Government (Shires) Act 1905 (Act No. 33,1905). This section specified business transacted at Council meetings was required to be recorded in a Minute Book Custody History. This information is recorded in the NSW Government Gazette

16 May, 1906 p. 2979 - 2981. This series was in the custody of the Mitchell library from 1965 until December 2001 when it was transferred to State Records NSW under section 29 of the State Records Act, 1998.

Following the amalgamation of Colo Shire with the Windsor Municipal Council, the building has been used as a pre-school and as the RFS Hawkesbury Fire Control Headquarters. What is not noted is that McKay Architects of Emu Plains added a 2-storey wing with VIP administration and Council Chamber in 1979. Two years later Colo Shire Council was amalgamated with Hawkesbury Shire and the building was then also put to other community uses by Hawkesbury Shire Council

COLO SHIRE—Election of Councillors.		
CANDIDATES		VOTES POLLED
<b>A RIDING.</b>		
Anderson, Arthur Charles	..	63
Casa, William George	..	47
Gosper, William Henry	..	52
McMahon, James Joseph	..	19
Tuckerman, Cyril Joseph	..	32
Wholohan, Henry Joseph	...	29
<b>B RIDING.</b>		
Bowd, Edward Thomas	..	154
Greentree, Reuben	..	54
Nicholls, George	..	137
Wilson, Henry Albert	..	196
<b>C RIDING.</b>		
Dunston, John	..	57
Lamrock, John	..	76
McMahon, James Edward	..	64
<p>I declare Arthur Charles Anderson and William Henry Gosper duly elected for A Riding; Henry Albert Wilson and Edward Thomas Bowd duly elected for B Riding; John Lamrock and James Edward McMahon duly elected for C Riding.</p> <p style="text-align:right"><b>J. B. JOHNSTON,</b> Returning Officer.</p> <p>Windsor, 26th November, 1906.</p>		

The above extract: *Windsor and Richmond Gazette* 1 Dec 1906 declaring the results of the first election of councillors for the new Colo Shire Council

<https://trove.nla.gov.au/newspaper/article/85665648>

Further information about Colo Shire Council is available from the Local Studies Collection, Hawkesbury Library Windsor. Also see, *Hawkesbury 1794-1994: The First 200 Years of the Second Colonisation*, Hawkesbury City Council 1994 by Jan Barkley-Jack & Michelle Nichols

NOTE: *Wallambine* is a locality to the north of St Albans, NSW situated on *Wallambine* Creek. Historical references to the *Wallambine* are well documented. The *Wallambine* was identified and recorded by Surveyor General Thomas Mitchell and his assistant surveyors as they undertook survey of land north of the Sydney settlement in the late 1820's. The country north of the Hawkesbury to around Broke was known generally as the *Wallambine* in the 1820's and 30's, and the Aboriginal People as the *Wallambine* blacks, with their northern border the Kamilaroi. When Mitchell mapped out the township of Wollombi, he adopted Wollombi as the English spelling of *Wallambine*, and named this English version for the creek and township he planned, but didn't change *Wallambine* swamp as the name of the headwaters of the Macdonald River in his 1834 map. (Allan E J Andrews 1992, Major Mitchell's Map and A Woods 1987 *Dawn in the Valley*)

K-CHS Members were invited to hold a book and history stall at the KURRAJONG PUBLIC SCHOOL Spring Fair 19th August 2023. Below are images of a Mill House & Mill Wheel Model created and set up on the day by member Bryan Wyborn

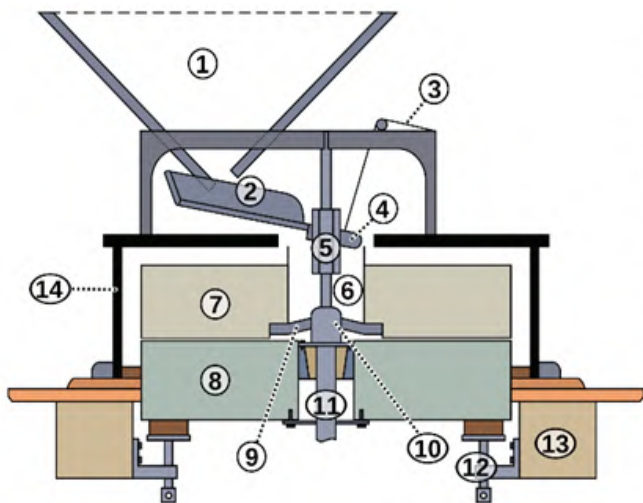

1. Hopper
2. Shoe
3. Crook string
4. Shoe handle
5. Damsel
6. Eye
7. Runner stone
8. Bedstone
9. Rind
10. Mace
11. Stone spindle
12. Millstone support
13. Wooden beam
14. Casing (Tentering gear not shown)

Diagram by Emmanuel Boutet.

Cross sectional side view showing the key components of a grain mill.



Frank Holland explaining the workings of the Mill House operations to inquisitive children.

**Operation of the Grinding Stones**

Singleton’s two water mills were erected c.1820, approximately 4km north of Kurrajong Village, on Little Wheeny Creek. They continued to operate until c.1858, grinding locally grown wheat, corn and other grains. In operation, the top runner stone was rotated by the power of the water turning the water wheel and the bottom bed stone was stationary. The runner stone was suspended a small distance above the bed stone and this gap was adjusted by the miller, depending on the grain being milled and the speed of the rotation. The grain was fed in through the centre of the runner stone and was forced outwards by the patterns on the stones until it emerged as flour from the outer edge.

Grinding Stones  
K-CHS Logo

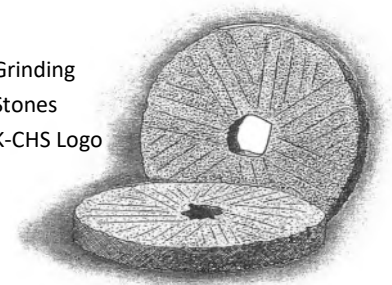

**CAREY**  
and co.

Specialty boutique & Giftware

Shop 1/64 Old Bells Line of Rd,  
Kurrajong NSW 2758  
(02) 45731920

Restaurant Open 6 Days  
77 Old Bells Line of Road  
Kurrajong  
Ph: 02 4576 0500

Monday, Tuesday, Wednesday,  
Friday, Saturday 11.30am - 10pm  
Sunday 11.30am - 4pm  
(Closed Thursday)

**SCHEMBRAE'S**  
AT KURRAJONG

Blending Mediterranean Cuisine using local produce  
admin@schembraes.com.au www.schembraes.com.au



**Esther Gray** was the only child of the Rev Maurice and Emily Gray, the Rector and his wife, of St Stephen's Church of England, Kurrajong (1891-1901). When about 16 years old, Esther drew a picture of Singleton's Mill in Little Wheeny Creek. Esther was born 1875 and married Arthur Dunston in 1898. Esther passed away aged 83 in 1958

For more details visit K-CHS People Archives: [People Database \(kurrajonghistory.org.au\)](http://kurrajonghistory.org.au)

**Marriage of Esther Gray & Mr Arthur Dunston**

*A very pretty marriage, and one of considerable local importance, took place in St Stephen's Church Kurrajong, on Wednesday Sept 28<sup>th</sup> 1898. The happy persons were Mr Arthur Dunston and Miss Esther Gray, daughter of Rev. M Gray, Rector of this Parish ...the day was all that nature could give ...fine, bright and sunny. The church was beautifully and artistically decorated by the members of the choir. There was a large and handsome arch of ferns and flowers over the chancel, with a large floral bell suspended from the centre, another similar arch over the middle of the aisle, and a great profusion of ferns and flowers and leaves, tastefully and fantastically arranged in the various other parts of the sacred edifice.*

Friends and family began arriving from Brisbane, Sydney, Windsor, Richmond and various parts of the district for a 1 o'clock ceremony and as the bride and her attendants entered the building the choir rose to sing, the beautiful Benedictine hymn: *The Voice that breathed o'er Eden, that earliest wedding day, the primal marriage blessing. It hath not passed away.*

*The marriage was performed by the bride's father Rev M Gray, with the other clergy present assisting in the service. Following from the Rectory, roses were scattered on the path before them, to the sweet strains of the "Wedding March". The bride looked very pretty in a simple gown of white muslin, with a tulle veil. She carried an ivory prayer book, the gift of the bridegroom ...she wore lilies of the valley and natural orange blossoms. The bridal cake, a unique piece of confectionary, was made by Mrs G Kirwan of Windsor, sister of the bridegroom. Following the reception they drove away amid showers of rice and flowers and the vociferous expressions of best wishes from friends.*

The above extract was first published in the Windsor & Richmond Gazette Saturday 8<sup>th</sup> October 1898. Later in the "St Stephen's Church Kurrajong Parish Registers 1861 – 1902" by The Family History Group, Kurrajong-Comleroy Historical Society. The Parish Registers publication is available for sale. Visit the K-CHS website for details: [K-CHS - Publications \(kurrajonghistory.org.au\)](http://kurrajonghistory.org.au)



Esther Gray's Sketch c1878  
Singleton's Mill Kurrajong



Arthur Dunston built the fine stone house *Westbury* on the next hill to St Stephen's in 1897, in readiness for his bride. Three succeeding generations of the family married at St Stephen's. The *Westbury* house image below - 1947. Visit the K-CHS Image archives 052703

It is with a note of sadness that the K-CHS committee wish to inform our membership of the passing of one of our newest members **Shirley Hetherington**. Our sincere condolences to Shirley's family & many friends.



Westbury 1947

**KURRAJONG CELLARS**  
**FINE WINE & SPIRITS**

**76 Bells Line of Road Kurrajong Village**

Christine Mead J.P Ph: 02 4573 1231  
Mobile: 0418 407 501  
Fax: 02 4573 1827 [kurrajongcellars@bigpond.com](mailto:kurrajongcellars@bigpond.com)

**Wines with a difference, beer, spirits & ice**

## Dates for Your DIARY



CHRISTMAS GREETINGS & the best of wishes to all our K-CHS members for a healthy & happy NEW YEAR 2024 from the K-CHS Committee. We look forward to seeing you all at the Christmas Gathering.

Australian Christmas Bush *Ceratopetalum gummiferum*



RICHMOND Looking West 1854 by FC Terry  
Image: Hawkesbury Library archives.

### K-CHS Christmas Gathering at *Glenhuntly*

5pm Saturday 9th December 2023

Bring your own meat for the barbecue, own drinks & alcohol

A variety of salads & desserts will be available  
Tea, Coffee & Cake

Members & Friends Welcome

Free event but please book on the K-CHS website

### WELCOME to NEW MEMBERS

The Society would like to welcome new members

**Janet & Gregory KAPP**

**Matt SUMEGHY**

**John LINES**

### The Cattai Audio Walk is now online!

[Cattai Audio Walk : 11 Stories from the River Dyarubbin - YouTube](#) The audio offers an interesting balanced view of interactions between 1<sup>st</sup> Nations People, explorers and early settlers along the Hawkesbury, in our region. Walk alongside the river, Cattai Creek and the lagoon in Cattai National Park as you listen to these stories of place and get to know Cattai!

Where Cattai Creek meets Dyarubbin, the river leaves the floodplain and starts returning into sandstone country. Dharug artist Leanne Mulgo Watson is

our guide as we learn this is the start of a sacred zone to the Dharug, an area rich with rock engravings, a meeting place & ceremonial ground. We learn of the first two recorded meetings between European exploratory parties and Dharug people at Little Cattai and Cattai Creeks in 1789 & 1791, the colonisation & frontier conflict that followed and how this place was later granted to Surgeon Thomas Arndell.

We hear of the ongoing Aboriginal presence in the area, Kurringy the leader of the Caddie Creek Tribe. Of Thomas Arndell's meeting with Yarragowhy and

Yarramundi in 1804. Many generations of the Arndell family farmed here, at the homestead and at *Hope Farm Mill*. *Ebenezer Church* is just over the river. The impact of continual flooding which saw the Arndell family sell the property to National Parks in the 1980s. We learn of sand mining, waste water and weed management in the catchment. Work of the Hawkesbury Nepean Catchment Management Trust, Hawkesbury Nepean Waterkeeper Alliance and a Platypus study on Cattai Creek. **Cattai** is 9th in the series of Audio Walks, which can all be found on the **Hawkesbury Regional Museum's Website**.



For all of your property needs be sure to get in touch with the team at  
**Ray White Kurrajong**  
4573 1000 or kurrajong.nsw@raywhite.com

### The Village Kitchen Kurrajong

83 Old Bells Line of Road Kurrajong Village

Dine In Gallery – Fully Licensed  
Wednesday to Sunday 8am - 2pm  
Evening Friday & Saturday from 5pm

**For BOOKINGS phone 02 4573 0988**  
[www.thevillagekitchenkurrajong.com.au](http://www.thevillagekitchenkurrajong.com.au)